



Pheenix Alpha's New Stand-Alone Extruder - Precision, Portability, and Performance

Pheenix Alpha's Stand-Alone Extruder Built with the latest engineering standards and complying with European CE safety regulations, the extruder delivers superior performance.

FEATURES

- A coated screw optimized for gentle extrusion and homogeneous temperature distribution.
- A four-zone electrical heating system and three-zone air cooling for precise process control.
- Beckhoff PLC software with a 7" touchscreen for enhanced control and accessibility.

OPTIONAL

- Frequency converter to control Screw Speed.
- Wheels to move the Extruder around in the production.

Pheenix Returns to Manual Production for Smaller Runs and Creative Vinyl Projects.

Pheenix is proud to announce the return of manual production, complementing our flagship automatic AD12 system. This expansion enables us to better meet the needs of smaller operations and customers seeking maximum flexibility and creativity.

By reintroducing the manual process, we are now able to offer unique and customized vinyl pressings, including sought-after formats such as picture discs, splatter patterns, and multi-colored vinyl. This move reflects our commitment in supporting independent artists, boutique labels, and anyone looking to create truly extraordinary vinyl records.

We have seen a growing demand for highly creative designs and smaller production runs; by reintroducing manual production the press allows us to provide even greater flexibility and innovation to our customers.

Pheenix has a long-standing tradition of excellence and innovation in vinyl production. This initiative is part of our broader strategy to strengthen customer relationships and continue delivering top-tier craftsmanship and quality.

This new manual system is based on the trusted AD12 platform, ensuring compatibility with many of its spare parts, offering a clear advantage to our customers in terms of maintenance and reliability.

Flexibility with Dual Press Options

The AD12 Manual also allows customers to expand their setup with **two presses serviced by a single extruder**, enabling efficient production at a higher scale. Additionally, customers can choose **extra extruders** for the creation of multi-colored vinyl records, providing more options for creative and artistic projects.

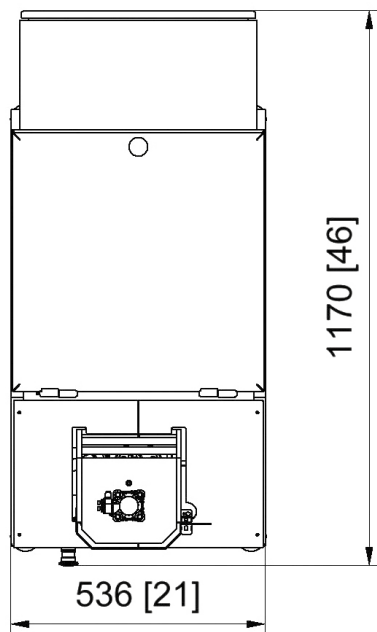
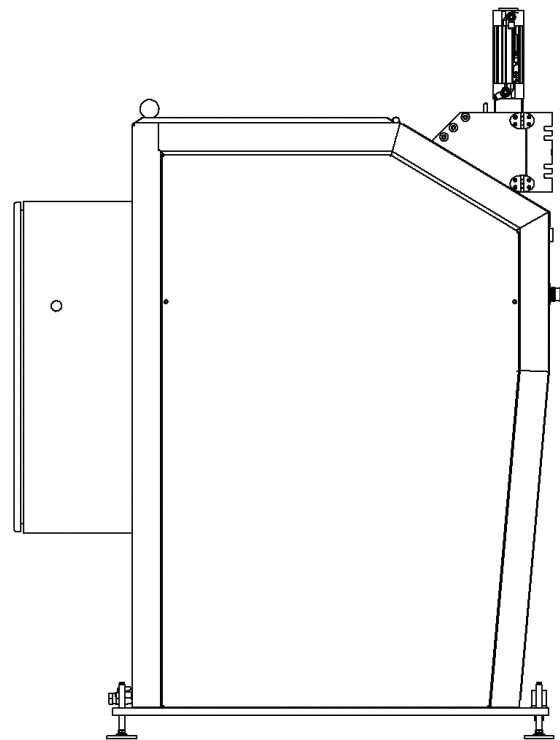
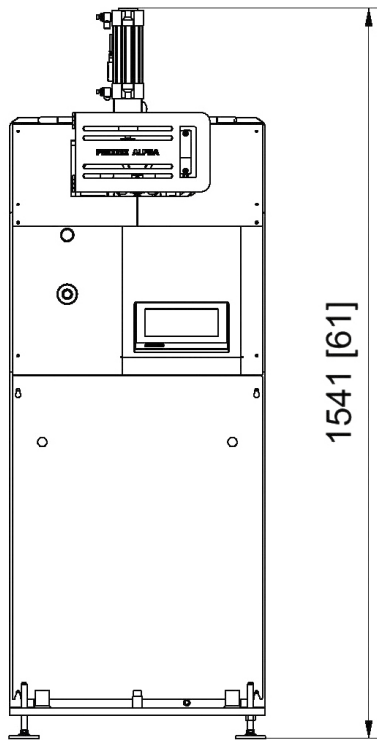

Media supply requirements for one Pheenix Stand-Alone Extruder

ELECTRICAL INPUT	3x400/3x480 V+PE 50-60 Hz 25 Amp singel fase
COMPRESSED AIR PRESSURE	6-9 Bar, 100 l/min

Please
contact us with
any questions or
to make a
request.

