



## Streamlined and Responsible Stamper Production

Optimize your stamper production with our robust passivation, cleaning, and drying unit. It removes lacquer residues and preserves both 'father' and 'mother' stampers using eco-friendly anodic passivation.

### FEATURES

- Rigid design in stainless steel, polypropylene and titanium
- Integrated pump and filtration
- Exhaust ready
- Integrated temperature control
- Anodic passivation and cathodic cleaning for both nickel and DMM
- Sink with foot-controlled spray faucet
- Spin table with adjustable speed up to 120 RPM
- Storage shelf

## INNOVATIVE AND USER-FRIENDLY ELECTROFORMING SOLUTIONS

Discover the ultimate in electroforming technology with Pheenix Alpha - your go-to choice for stamper production and electroforming solutions. Our system boasts an intelligent and intuitive design that sets it apart in the market. Equipped with a powerful new processor, it adapts to your specific needs with customizable software options.

Pheenix Alpha offers features that empower operators to maintain peak productivity and ensure top-notch quality. Real-time process monitoring provides timely alerts for cartridge replacements, nickel pellet replenishment, and anode basket cleaning. Experience consistent, high-quality production with minimal downtime.

Our system is controlled by an industrial-grade PLC for unmatched reliability. Enjoy user-programmable recipes with exceptional repeatability.

With all components neatly contained within its footprint, our cabinet provides location flexibility, ensuring a seamless fit into your workspace.

Pheenix Alpha's dedicated technicians bring expertise and experience to the table, from development and manufacturing to servicing electroforming systems. We're the world's only manufacturer offering both electroforming and replication systems. Experience the convenience of a one-stop shopping concept for lacquer and DMM family development.

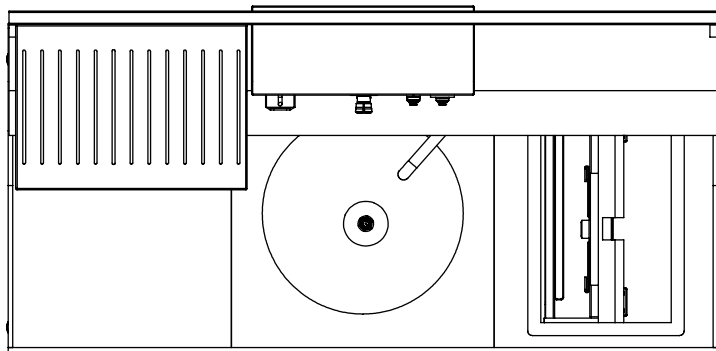
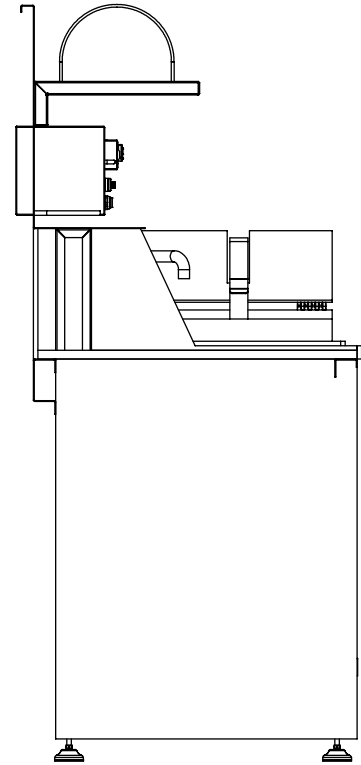
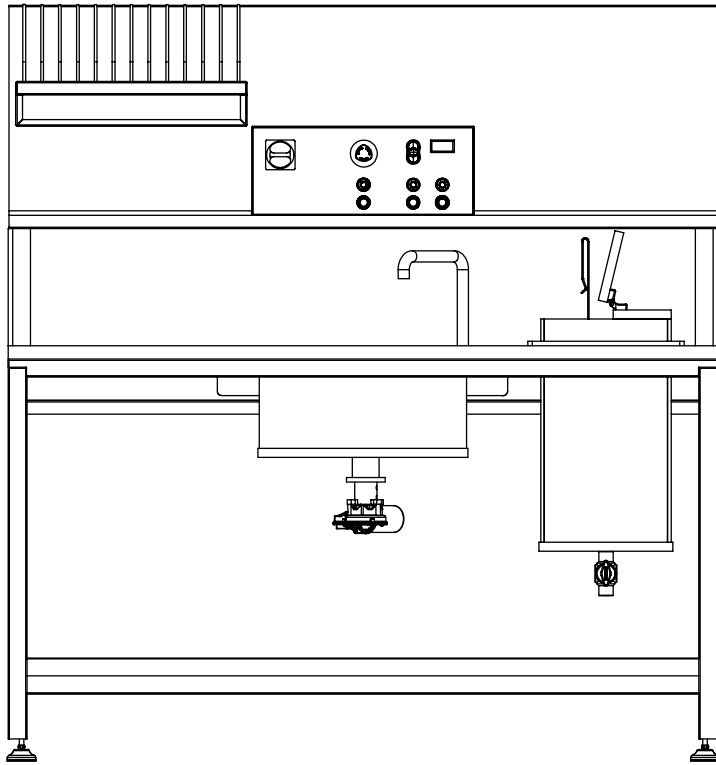

*Please contact us with any questions or to request.*

**Media Supply requirements for one Phoenix Modular Preparation Bench**

<b>DIMENSIONS</b>	W 1588 mm × D 775 mm × H 1700 mm
<b>WORKING HEIGHT</b>	920 mm
<b>ELECTRICAL INPUT</b>	100-230 VAC +/- 5%, 50-60Hz, 10 Amp. single phase
<b>SCCR</b>	10kA
<b>D.I. WATER CONNECTION</b>	G3/4", 20 mm
<b>DRAIN CONNECTION</b>	Ø 32 mm

THE INFORMATION PROVIDED MIGHT BE SUBJECT TO CHANGES.



**Phoenix Alpha AB**  
 Skepptuna Borgen 299  
 SE 195 93 Märsta  
 +46 (0)8 598 933 00  
[www.phoenixalpha.com](http://www.phoenixalpha.com)

**E-mail** [info@phoenixalpha.com](mailto:info@phoenixalpha.com)  
**Spareparts order handling**  
[order@phoenixalpha.com](mailto:order@phoenixalpha.com)  
**Helpdesk/support**  
[helpdesk@phoenixalpha.com](mailto:helpdesk@phoenixalpha.com)

