



## Compact and Flexible Silvering Solution

Experience efficiency and precision with our Silvering Unit. It features a compact design, adjustable rotation speed and four automatic nozzles for consistent silver application.

### FEATURES

- Rigid design in stainless steel and polypropylene
- Adjustable rotation speed up to 120 RPM on the cleaning station
- Rotation speed 45 RPM on the silver spray unit
- Automatic spraying sequence with four nozzles
- Foot-controlled spray faucet
- Overspill collection
- Exhaust ready
- Silver unit can be positioned on either right or left side of the cleaning bench

## INNOVATIVE AND USER-FRIENDLY ELECTROFORMING SOLUTIONS

Discover the ultimate in electroforming technology with Pheenix Alpha - your go-to choice for stamper production and electroforming solutions. Our system boasts an intelligent and intuitive design that sets it apart in the market. Equipped with a powerful new processor, it adapts to your specific needs with customizable software options.

Pheenix Alpha offers features that empower operators to maintain peak productivity and ensure top-notch quality. Real-time process monitoring provides timely alerts for cartridge replacements, nickel pellet replenishment, and anode basket cleaning. Experience consistent, high-quality production with minimal downtime.

Our system is controlled by an industrial-grade PLC for unmatched reliability. Enjoy user-programmable recipes with exceptional repeatability.

With all components neatly contained within its footprint, our cabinet provides location flexibility, ensuring a seamless fit into your workspace.

Pheenix Alpha's dedicated technicians bring expertise and experience to the table, from development and manufacturing to servicing electroforming systems. We're the world's only manufacturer offering both electroforming and replication systems. Experience the convenience of a one-stop shopping concept for lacquer and DMM family development.

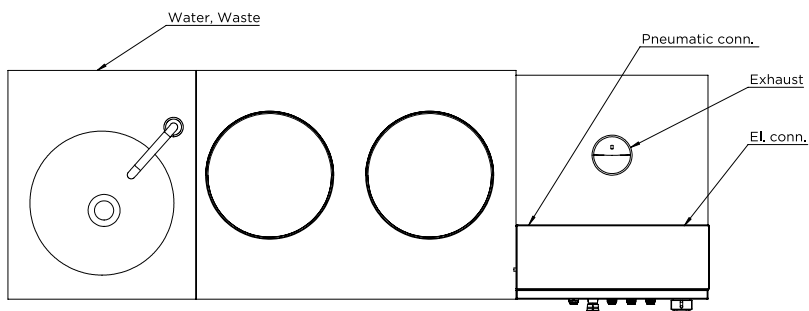
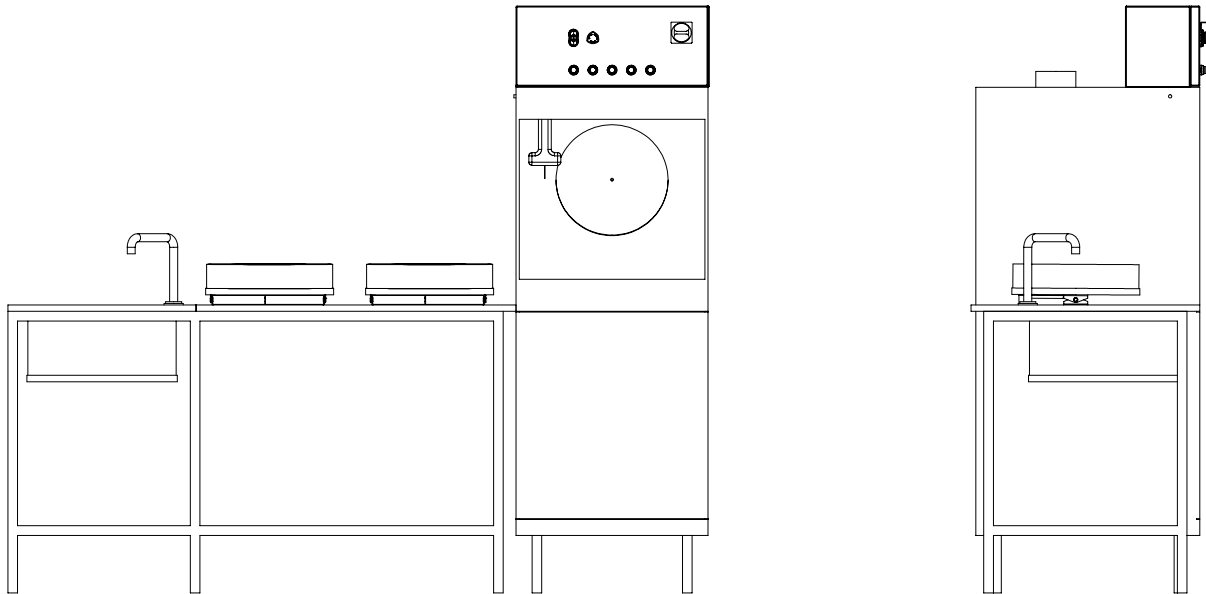

**Media supply requirements for one Phoenix Automatic Silvering Unit**

|                         |   |
|-------------------------|---|
| <b>DIMENSIONS</b>       | W 2188 mm x D 715 mm x H 1835 mm                  |
| <b>WORKING HEIGHT</b>   | 900 mm  |
| <b>ELECTRICAL INPUT</b> | 100-230 VAC +/- 5%, 50-60Hz, 10 Amp single phase. |
| <b>SCCR</b>             | 10kA  |
| <b>WATER</b>            | Ø 20 hose connection, 2 x G3/4"                   |
| <b>PNEUMATIC CONN.</b>  | G1/2", 6 Bar                                      |
| <b>EXHAUST</b>          | Ø 125, 150m <sup>3</sup> /h                       |
| <b>DRAIN CONNECTION</b> | Ø 32 mm   |

Please contact us with any questions or to request.



**Phoenix Alpha AB**  
 Skepptuna Borgen 299  
 SE 195 93 Märsta  
 +46 (0)8 598 933 00  
[www.phoenixalpha.com](http://www.phoenixalpha.com)

**E-mail** [info@phoenixalpha.com](mailto:info@phoenixalpha.com)  
**Spareparts order handling**  
[order@phoenixalpha.com](mailto:order@phoenixalpha.com)  
**Helpdesk/support**  
[helpdesk@phoenixalpha.com](mailto:helpdesk@phoenixalpha.com)

